

SST-05-IR-H

Surface Mount Infrared LED

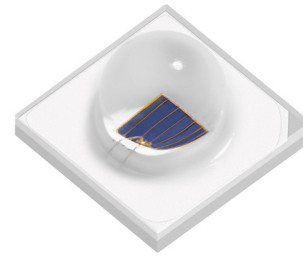

Features

- Infrared LED with a typical peak wavelength of 850 nm.
- 40 and 70-degree viewing angles options for high-irradiance and directional applications.
- Built-in ESD protection.
- Low thermal resistance.
- Suitable for all SMT assembly methods.



Applications

- Surveillance Systems / CCTV
- Iris and Face Recognition
- License Plate Scanning
- Automotive Sensing
- Machine Vision
- Night Vision
- Replacement of legacy 5 mm² IR LEDs for improved designs

Table of Contents

Ordering Information.	2
Binning Structure.	3
Characteristics.	4
Angular Distribution and Typical Spectrum.	6
Absolute Maximum Ratings.	8
Mechanical Dimensions.	9
Mechanical Characteristics.	11
Soldering Profile.	12
Tape and Reel Outline.	13
Shipping Label.	15
Packaging.	16
Notes.	17
Revision History.	18



Ordering Information

Ordering Part Numbers¹

Peak Wavelength	Radiometric Flux		Lens Angle	Ordering Part Number
	Minimum Flux Bin ¹	Minimum Flux ²		
850 nm	J	235 mW	40	SST-05-IR-B40H-J850
			70	SST-05-IR-B70H-J850
	K	265 mW	40	SST-05-IR-B40H-K850
			70	SST-05-IR-B70H-K850

Part Number Nomenclature

SST	05	IR	BxxH	F###
Product Family	Chip Area	Color	Package Configuration	Bin Kit
S: Surface Mount S: Dome Lensed T: Single Emitter	05: 5 mm ² class chip	IR: Infrared	B40H: 40 deg viewing angle B70H: 70 deg viewing angle	Refer to flux bin and wavelength bin table in page3 for more details

Note:

1. The Ordering Part Number specifies the Minimum Flux Bin in shipment; higher flux bins may be shipped without advance notice. Please refer to 'Radiometric Flux Bins' table for details of all flux bins.



Binning Structure

Radiometric Flux Bins^{1,2}

Flux Bin	Binning @ 350 mA, $t_p = 20\text{ms}$, $T_c = 25^\circ\text{C}$		Correlated Minimum Flux (lm) @ $t_p = 20\text{ms}$, $T_c = 25^\circ\text{C}$	
	Minimum Flux (mW)	Maximum Flux (mW)	500 mA	800 mA
J	235	265	331	517
K	265	295	373	583
L	295	325	415	649
M	325	355	458	714
N	355	385	500	780

Wavelength Bins^{2,3}

Wavelength Bin	Binning @ 350 mA, $T_c = 25^\circ\text{C}$	
	Minimum Peak Wavelength (nm)	Maximum Peak Wavelength (nm)
850	840	870

Forward Voltage Bins^{2,3}

Forward Voltage Bin	Binning @ 350 mA, $T_c = 25^\circ\text{C}$	
	Minimum Voltage (V)	Maximum Voltage (V)
V2	1.4	1.6
V3	1.6	1.8

Notes:

1. Luminus maintains a $\pm 6\%$ tolerance on flux measurement.
2. Products are production tested then sorted and packed by bin.
3. Individual bins are not orderable. The wavelength bin as marked on the product label may be followed by a letter which is for internal use only.
4. T_c = Case temperature



Characteristics

Parameter ($I_f=350$ mA, $T_c=25^\circ\text{C}$)		Symbol	Package Type		Unit
			B40	B70	
Forward Current		I_f	350		mA
Typical Output Power		Φ_V	316		mW
Typical Output Power @ 800 mA, $t_r=20$ ms		$\Phi_V(800$ mA)	695		
Radiant Intensity		Φ_E	600	230	mW/Sr
Forward Voltage	Minimum	$V_{f\text{min}}$	1.2		V
	Typical	$V_{f\text{typ}}$	1.6		
	Maximum	$V_{f\text{max}}$	2.0		
Viewing Angle		$2\ \varnothing_{1/2}$	40	70	°
Typical Peak Wavelength		λ_p	850		nm
Typical Centroid Wavelength		λ_c	860		
FWHM- Spectral bandwidth at 50% of Φ_V		$\Delta\lambda_{1/2}$	30		
Electrical Thermal Resistance (junction to case) ²		$R_{\text{th JC elec}}$	7.2		°C/W

Note:

1. Binning based on operation at a current of 350 mA, 20 ms single pulse and a constant case temperature of $T_c = 25^\circ\text{C}$. Parts are binned and shipped in 0.2 V V_f increments.



Relative Radiometric Flux vs Forward Current

$T_j = 25^\circ\text{C}$

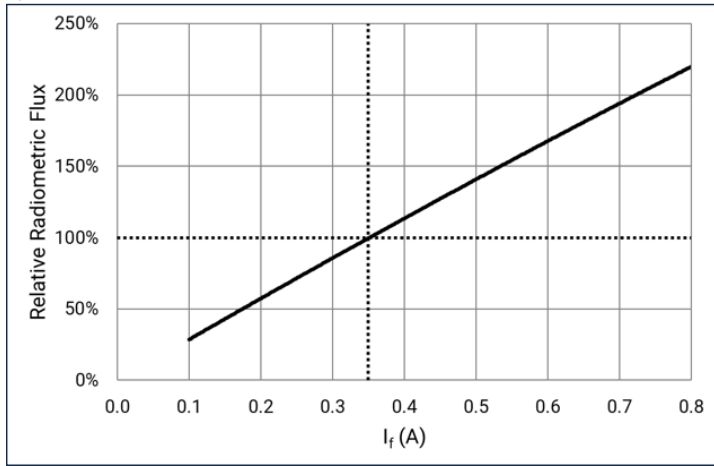

Relative Radiometric Flux vs Temperature

$I_f = 350\text{ mA}$

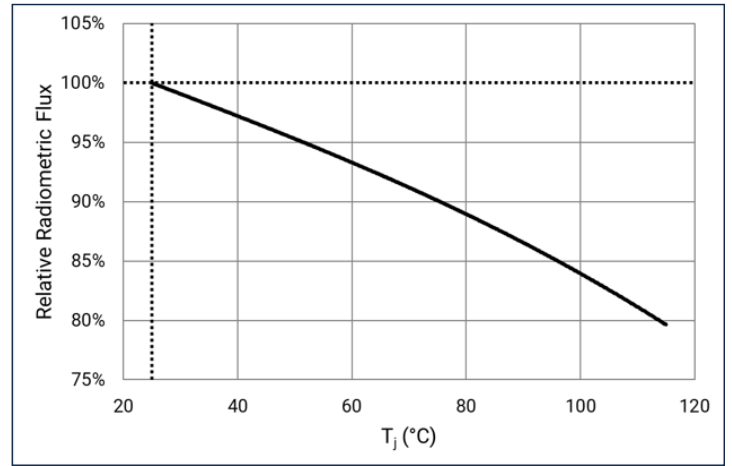

Forward Voltage vs Forward Current

$T_j = 25^\circ\text{C}$

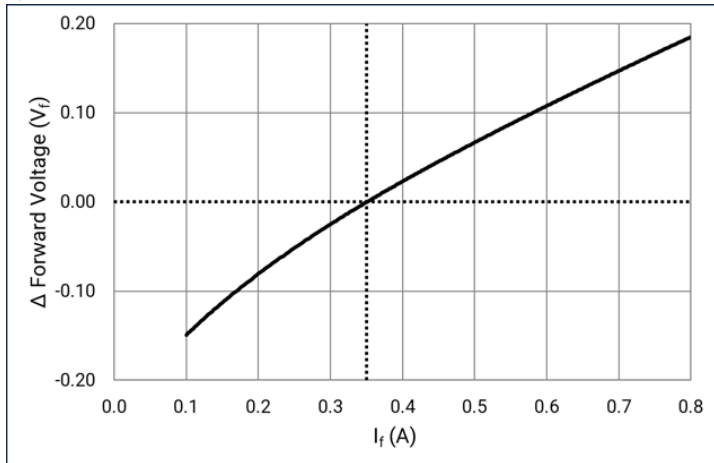

Forward Voltage vs Temperature

$I_f = 350\text{ mA}$

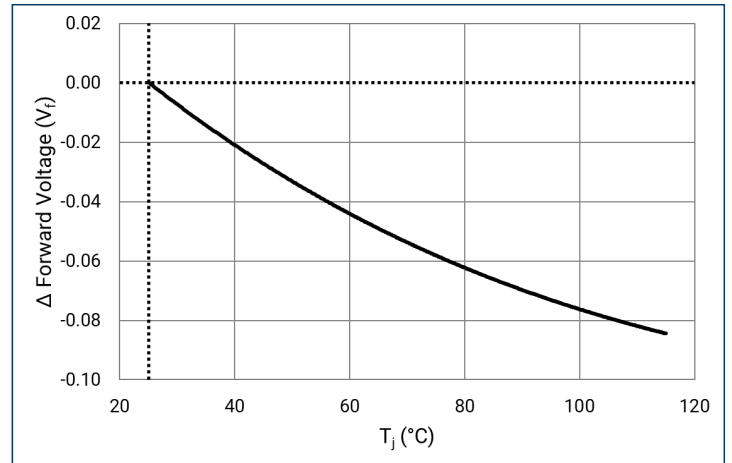

Peak Wavelength Shift vs Forward Current

$T_j = 25^\circ\text{C}$

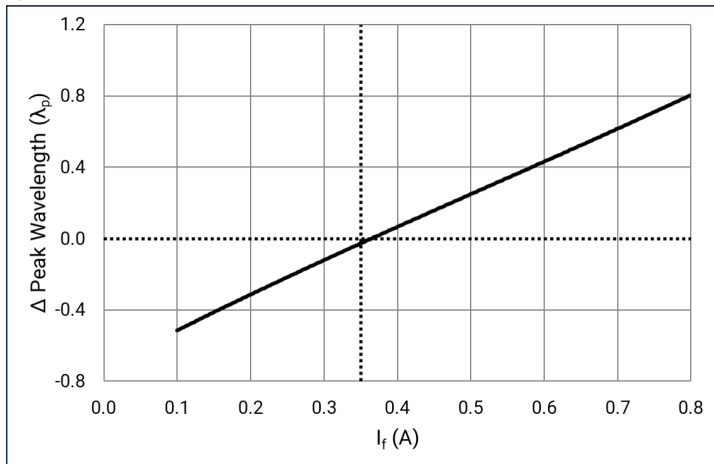

Peak Wavelength Shift vs Temperature

$I_f = 350\text{ mA}$

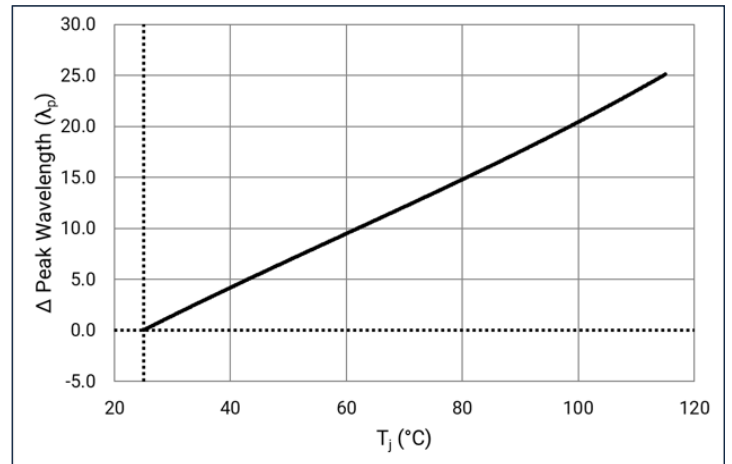



Angular Distribution

Typical Polar Radiation - B40

$I_f = 350 \text{ mA}$, $T_c = 25^\circ\text{C}$

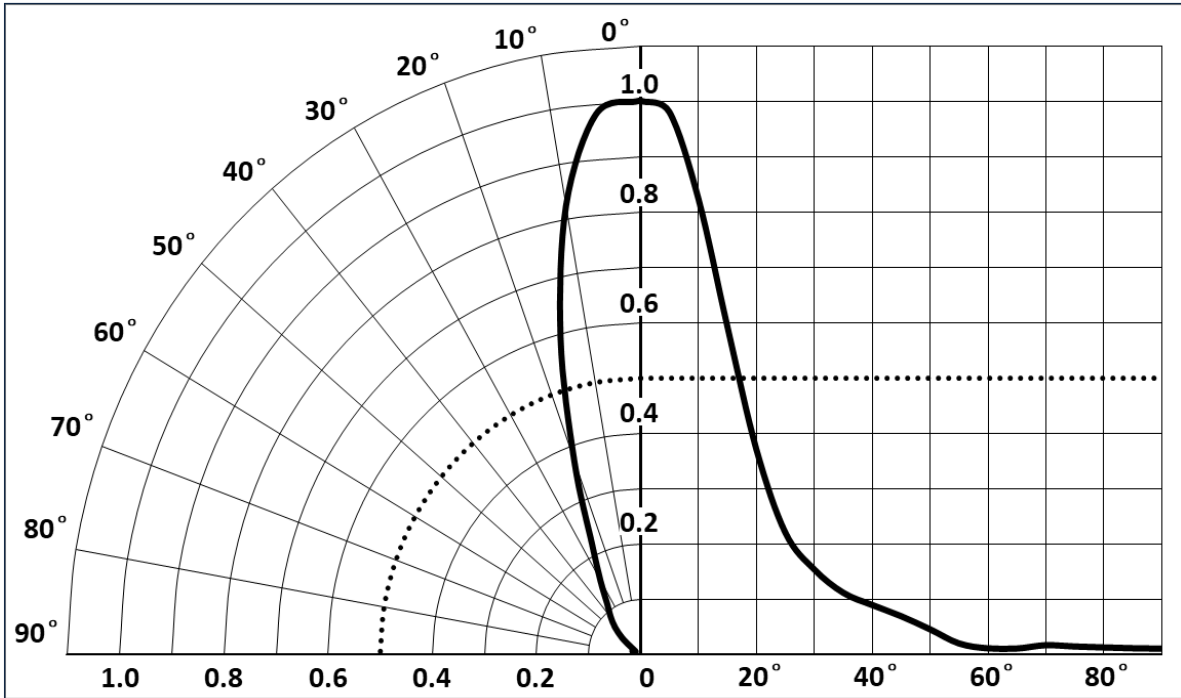

Typical Polar Radiation - B70

$I_f = 350 \text{ mA}$, $T_c = 25^\circ\text{C}$

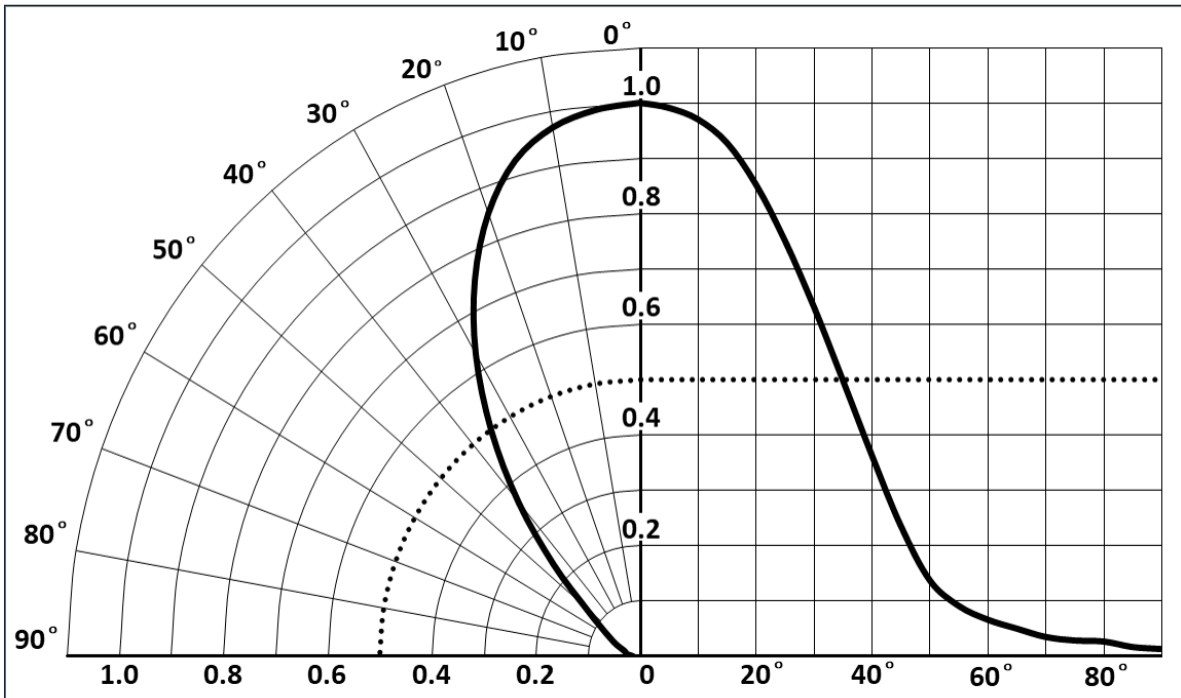



Typical Spectrum

Relative Spectral Power Distribution

$I_f = 350 \text{ mA}$; $T_c = 25^\circ\text{C}$

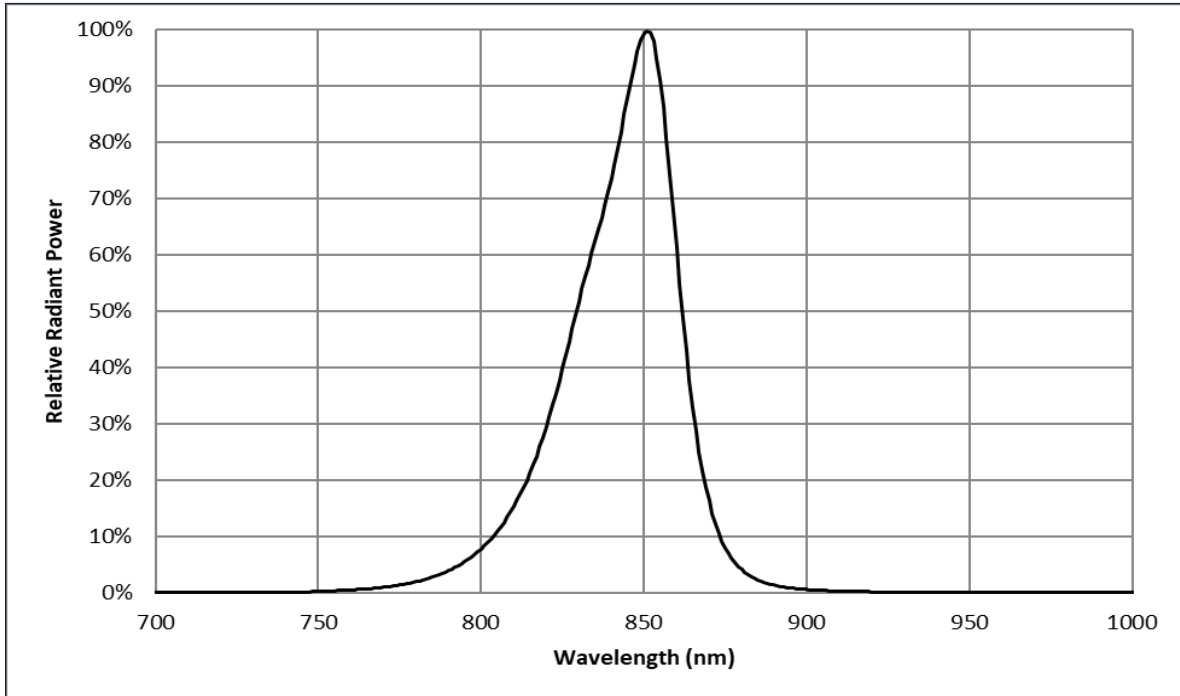



Absolute Maximum Ratings

Parameter	Symbol	Values	Unit
Forward Current (CW) ¹	$I_{f\ CW\ max}$	800	mA
Reverse Voltage	V_r	5	V
Storage Temperature Range	T_{stg}	-40 to 100	°C
Junction Temperature	T_j	115	
Soldering Temperature	T_s	260	
ESD withstand Voltage ANSI/ESDA/JEDEC JS-001 (HBM, Class 3B)	V_{ESD}	8	kV

Notes:

1. Luminus LEDs are designed for operation up to an absolute maximum forward drive current as specified above. Product lifetime data is specified at typical forward drive currents. Sustained operation at absolute maximum currents will result in a reduction of device lifetime compared to typical forward drive currents. Actual device lifetimes will also depend on junction temperature.



Mechanical Dimensions - B40 Package

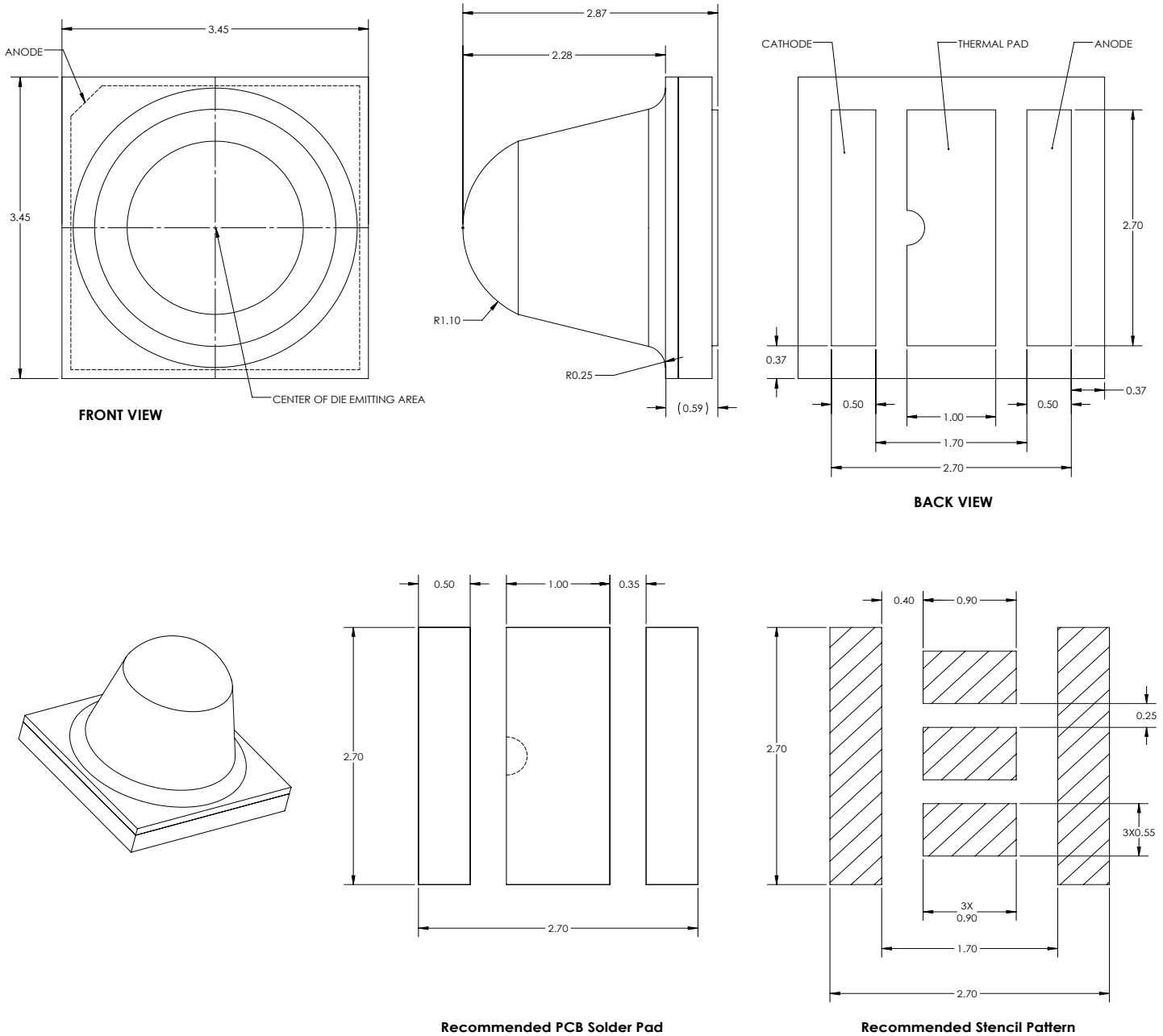

Note:

1. All dimensions are in millimeter ± 0.05 mm.



Mechanical Dimensions - B70 Package

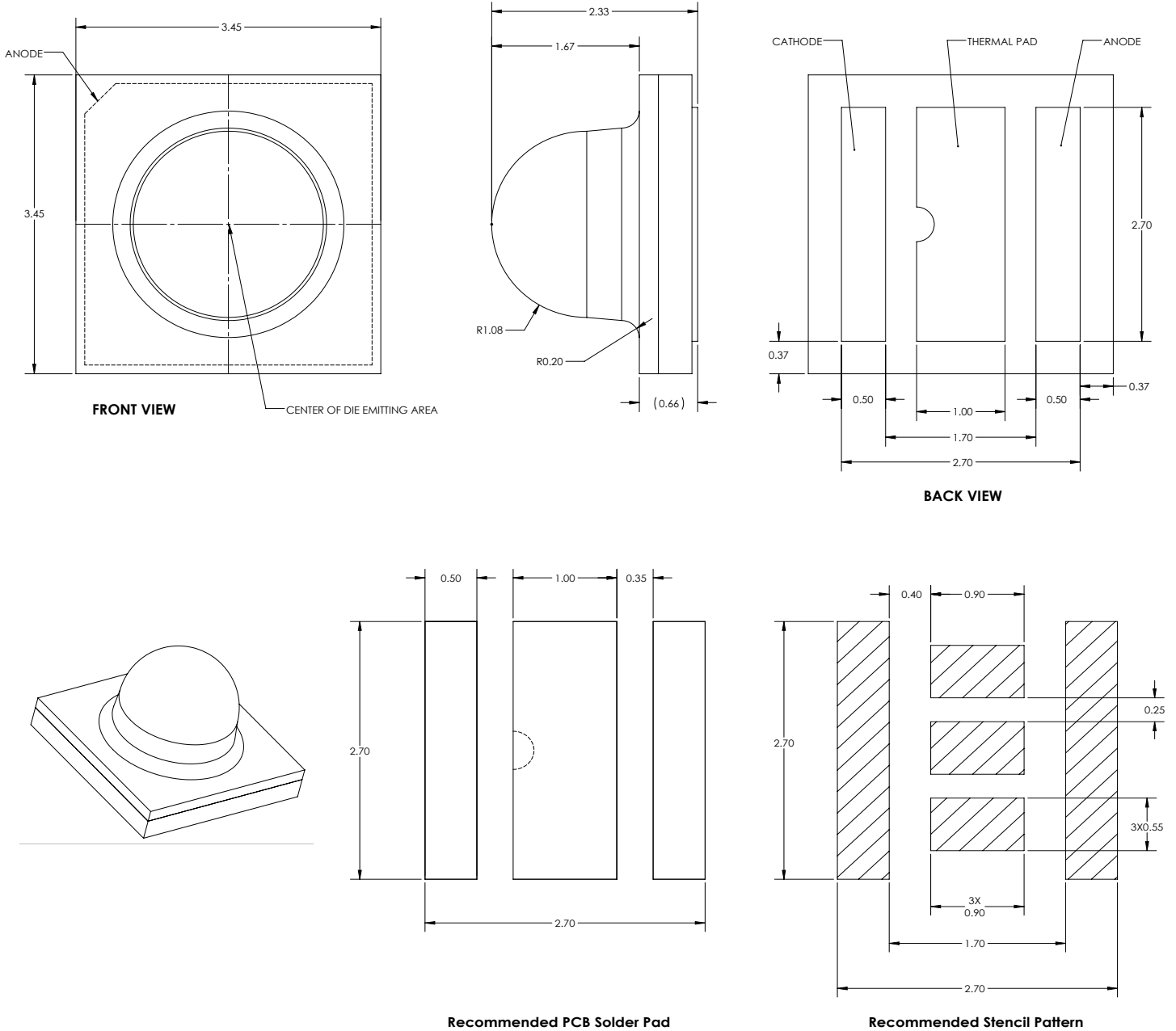

Note:

1. All dimensions are in millimeter ± 0.05 mm.



Mechanical Characteristics

JEDEC Moisture Sensitivity^{1,2}

Level	Floor Life	
	Time	Conditions
1	Unlimited	≤30°C / 85% RH

Notes:

1. Please note that the above MSL level based on the MSL qualification rating.
2. This LED has silver-plated pads, and for LEDs with silver plating, MSL3 environment control is required to protect silver-plated surface from oxidation, even though the products may be qualified as MSL1 or 2.



Soldering Profile

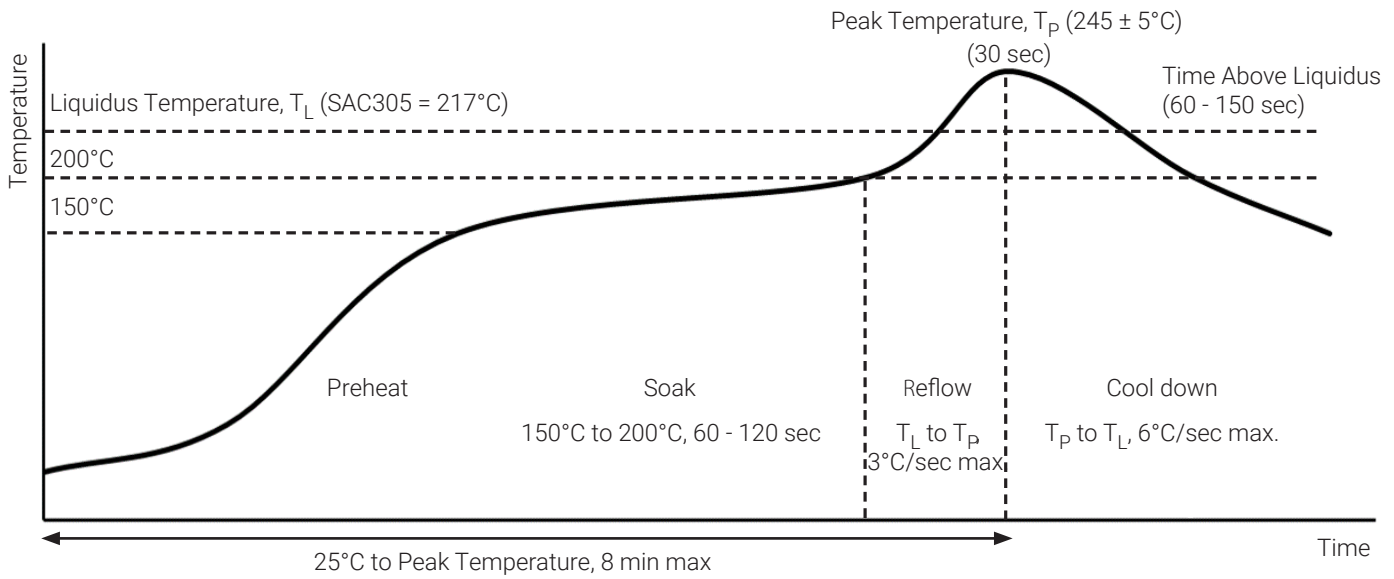

SMT Solder Rework Temperature Guidelines

Parameter	Manual Hotplate Reflow	Hot Air Gun Reflow
Heating Time	< 60 sec	
Hotplate Temperature	< 245°C	< 150°C

Notes:

- The numbers in the table are specific to SAC305. Luminus recommends using an SAC305 solder paste with a no-clean flux for RoHS compliant products.
- Use of a multi-zone IR reflow oven with a nitrogen blanket is recommended.
- Time-temperature profile of the reflow process showing the four functional profile zones are defined in IPC-7801. All the temperatures refer to the application PCB measured adjacent to the package body.
- The actual profile shall be optimized per the PCB design and configuration.
- Key visual and LED performance characteristics to consider include solder bridging, solder voiding, solder balling, LED component placement or shifting, potential contamination that may impact light emissions, and the functional performance of the LED.
- Luminus recommends to use the solder paste data sheet information as a starting point in time-temperature process development.
- These are general guidelines. Consult the solder paste manufacturer's datasheet for guidelines specific to the alloy and flux combination used in your application. For more information, please refer to: <https://luminusdevices.zendesk.com/hc/en-us/articles/360060306692-How-do-I-Reflow-Solder-Luminus-SMD-Components->
- For any technical questions about soldering process, please contact Luminus at techsupport@luminus.com.



Tape and Reel Outline - B40

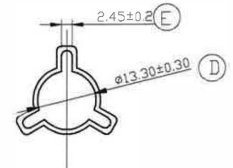
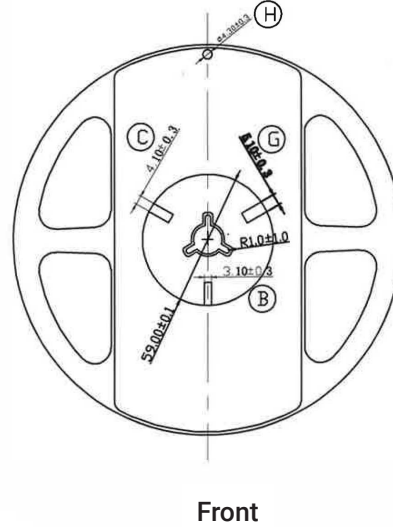
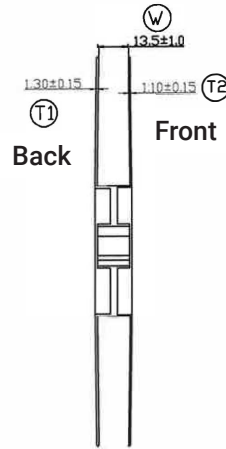
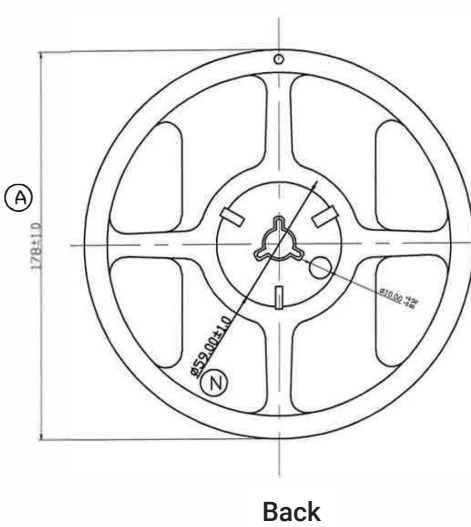
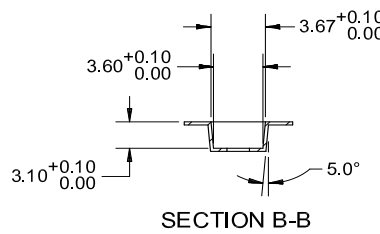
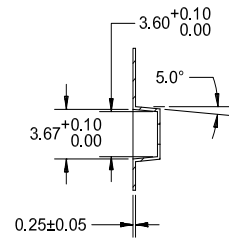
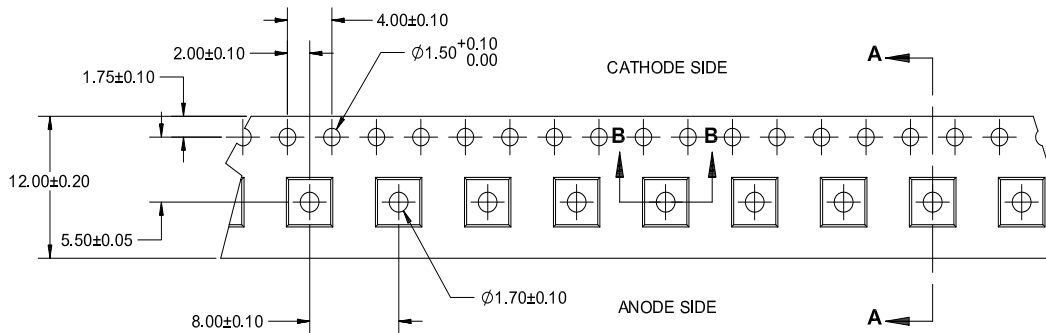

Notes:

1. Each reel contains 500 units.
2. Leave 304.8 mm [12.00 in] of type empty for lead in (38 empty pockets).
3. Leave 457.2 mm [18.00 in] of type empty for trailer (57 empty pockets).
4. Must comply to EIA-481-C-2003.
5. Final tape and reel packaging must meet the requirements of JEDEC-STD-033, LEVEL 2A.



Shipping Label

Label on Packaging Box

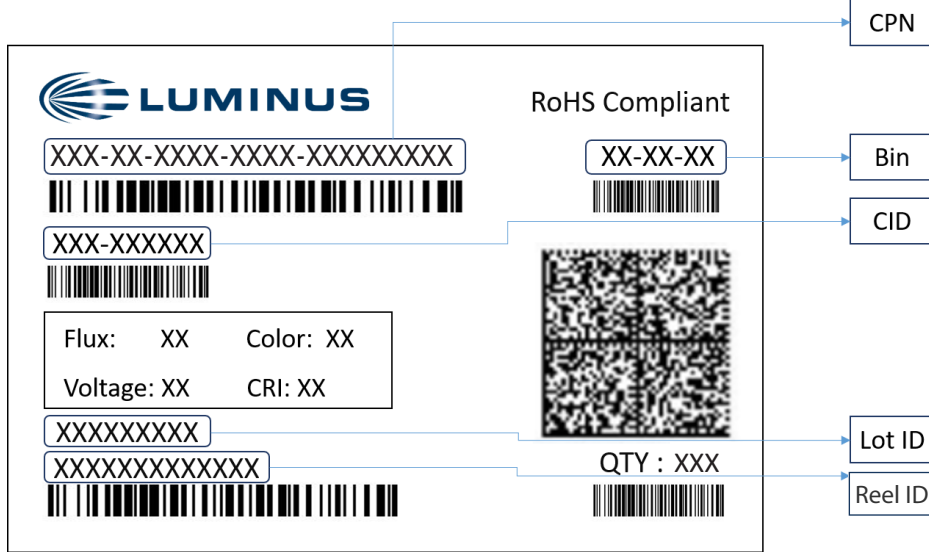

Label Fields:

- CPN: Luminus ordering part number
- CID: Customer's part number
- QTY: Quantity of parts per reel
- Flux: Bin as defined on page 3
- Voltage: Bin as defined on page 3
- Color: NA
- CRI: NA
- Lot ID & Reel ID: For Luminus internal use

Packing Configuration:

- 500 units per reel
- Partial reel may be shipped
- Each reel is placed in an anti-static moisture barrier bag
- The shipping label is placed on top of each packaging box



Packaging

Packaged Reel

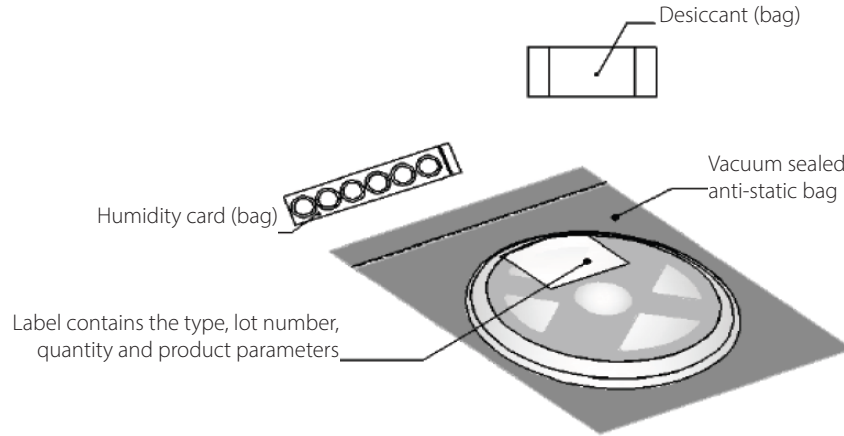

Packaging boxes

Box Size 1 - 5 reels per box
Size: 22.5 x 24.5 x 6.5 cm

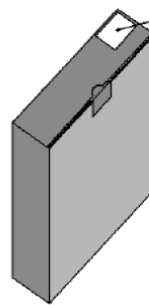
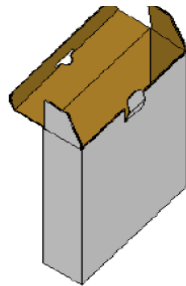

Label contains the type, lot number, quantity and product parameters

*Capacity 5 reels per box

Box Size 2 - 10 reels per box
Size: 22.5 x 24.5 x 13 cm

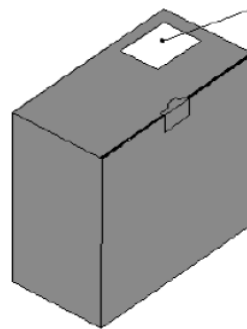
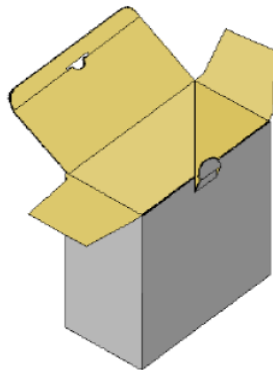

Label contains the type, lot number, quantity and product parameters

*Capacity 10 reels per box



Notes

Static Electricity

1. The products are sensitive to static electricity, and care should be taken when handling them.
2. Static electricity or surge voltage will damage the LEDs. It is recommended to wear anti-electrostatic gloves or wristband when handling the LEDs.
3. All devices, equipment and machinery must be properly grounded. It is recommended that measures be taken against surge voltage to the equipment that mounts the LEDs.

Reference: [APN-002815](#) Electrical Stress Damage to LEDs and How to Prevent It

Storage

The storage and baking treatment should be performed in accordance with the J-STD-033D guidance.

Corrosion Robustness

1. The LEDs were tested in accordance with the AEC-Q102 Rev 02 standard. Test condition used was: 40°C / 90 % RH / 15 ppm H₂S / 14 days.
2. The LEDs passed the optical and electrical Pass/Fail criteria as defined in AEC-Q102 Rev 02 – “Appendix 5: Parametric Test Requirements and Failure Criteria”
3. Corrosion test: Class 3B, based on the corrosion class definition as below:

Class	Grade A	Grade B	Test Condition
0	NA	Discoloration possible	Not Tested
1	No visible discoloration	Discoloration possible	25 °C / 75 % RH / 200ppb SO ₂ , 200ppb NO ₂ , 10ppb H ₂ S, 10ppb Cl ₂ / 21 days (EN 60068-2-60 (Method 4))
2	No visible discoloration	Discoloration possible	25 °C / 75 % RH / 10ppm H ₂ S / 21 days (IEC 60068-2-43)
3	No visible discoloration	Discoloration possible	40 °C / 90 % RH / 15ppm H ₂ S / 14 days (stricter than IEC 60068-2-43)



Revision History

Rev	Date	Description of Change
01	04/21/2025	Initial release
02	07/22/2025	Updated Tape and Reel and Mechanical Dimensions tolerance.